



IVENDO Solar
ul. Wojska Polskiego 2D
14-200 Iława

Manual for system installation on a flat roof

KDP-BIFACIAL-BK-WZ-I

These instructions contain information on how to assemble a superstructure for for 4 horizontally arranged modules.

Materials:

- Stainless steel A2
- Aluminum 6060 T66
- Structural steel with Magnelis coating S320 ZM430

It is essential that you familiarize yourself thoroughly with the instructions and use them in accordance with the intended purpose.

Information about the security

Before starting the assembly work, you should familiarize yourself with the following safety instructions, which will reduce the risk of an accident.



Attention! The setup and connection should be performed by qualified personnel with the appropriate authorizations. The general safety rules must also be observed.



Attention! During the work, it is necessary to observe the applicable national and European standards, especially the electrical installations. It is also necessary to follow the instructions of the other components, e.g. the inverter.



Attention! Danger of falling from heights. The rules for working at heights and the necessary safety equipment such as harnesses and safety ropes must be observed.



Attention! Danger of falling objects. Special care must be taken. Before starting work, the assembly area must be appropriately secured to avoid hazards.



Attention! Warning of electric current. Be particularly careful when performing electrical work, especially when connecting modules and when setting up and connecting the inverter to the modules.



Attention! Warning about highly flammable materials. Photovoltaic modules, inverters and other electrical equipment should not be used near easily flammable materials.



Attention! The assembly work must not be carried out by persons under the influence of alcohol or other intoxicating substances.

Elements list

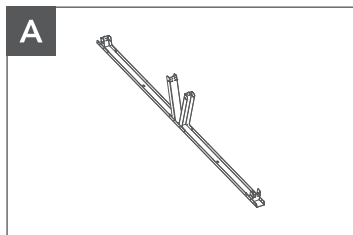

Fixing triangle

Material: Coated Steel Magnetism

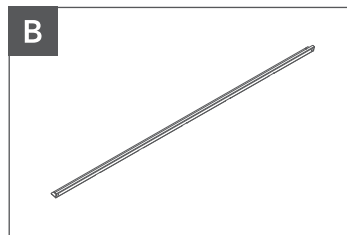

Module support Bifacial

Material: Coated Steel Magnetism

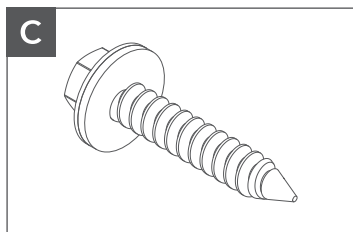

Self-tapping Screw

Material: Stainless steel

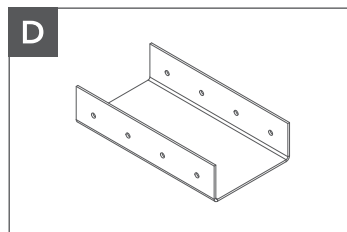

Triangular connector Mounting

Material: Coated Steel Magnetism

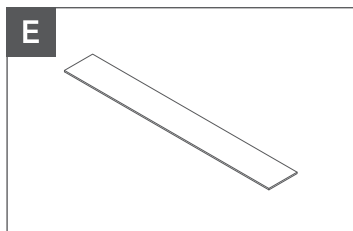

SBR rubber

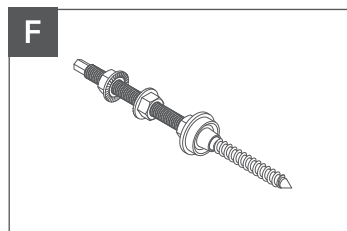

Double threaded bolt M10

Material: Stainless steel

Assembly instruction



Necessary tools:

- Allen wrench (size 5)
- Ring wrenches (size 13, 15 and 17 mm)
- Cordless screwdriver with Torque adjustment
- Cross-recess bits / attachments for the Cordless screwdriver (PZ)



Staffing for assembly:

- At least 2 persons



Tightening torques:

- Tighten middle and end clamps with a tightening torque of 8.5 Nm
- Tighten M8 bolts and nuts with a tightening torque of 18 Nm.
- Tighten M10 bolts and nuts with a tightening torque of 36 Nm



Assembly time:

- About 2 hours

Control and maintenance

During the installation work, it must be ensured that the photovoltaic system is used according to its intended purpose. All changes in the use of construction elements, including connection with elements that do not come from IVENDO Solar, the modification of the construction by welding, shortening, lengthening, drilling, etc., and increasing the load on the systems will result in the loss of warranty claims and may have a direct impact on the life of the systems and their safe use.

The technical inspection and maintenance of the mounting system should be carried out at least once every six months, special attention should be paid to:

- Bolted connections,
- The condition and connections of the electrical cables are checked,
- the visual condition of the PV modules (contamination, mechanical damage) is checked.

Assembly of the set

- 1 Before mounting, the installation plan for the modules (Fig. 1) and the mounting triangles (Fig. 2) must be determined. The way of fixing the mounting structure on the roof field depends on the type of roof and is chosen individually.

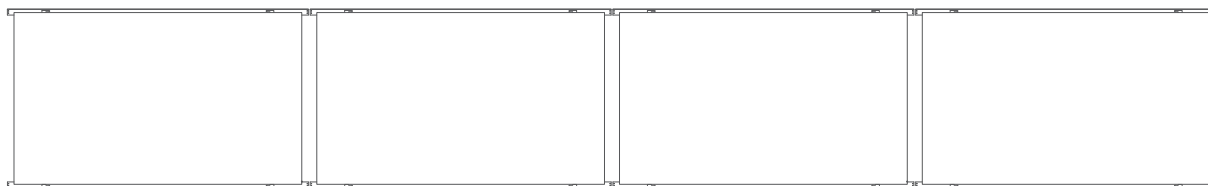

Fig. 1 Modular structure plan

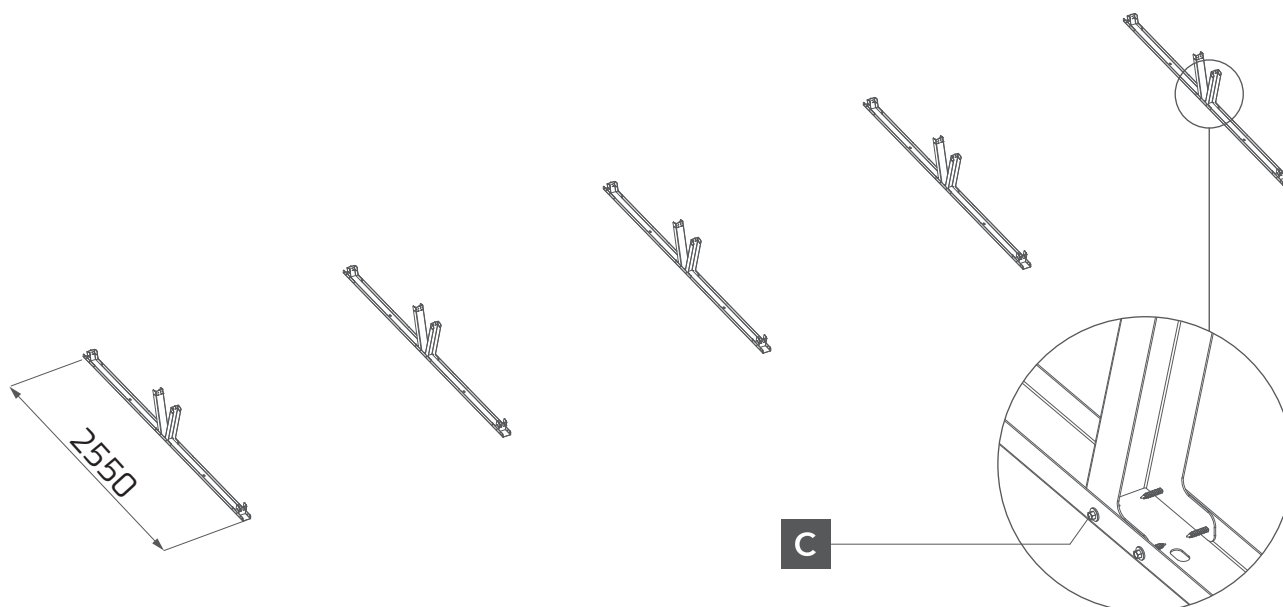

Fig. 2 Arrangement of the mounting triangles

- 2 Place the SBR rubber under the lower bottom of the mounting triangle. Then place the lower module holder on the mounting triangle and screw it with sheet metal screws.

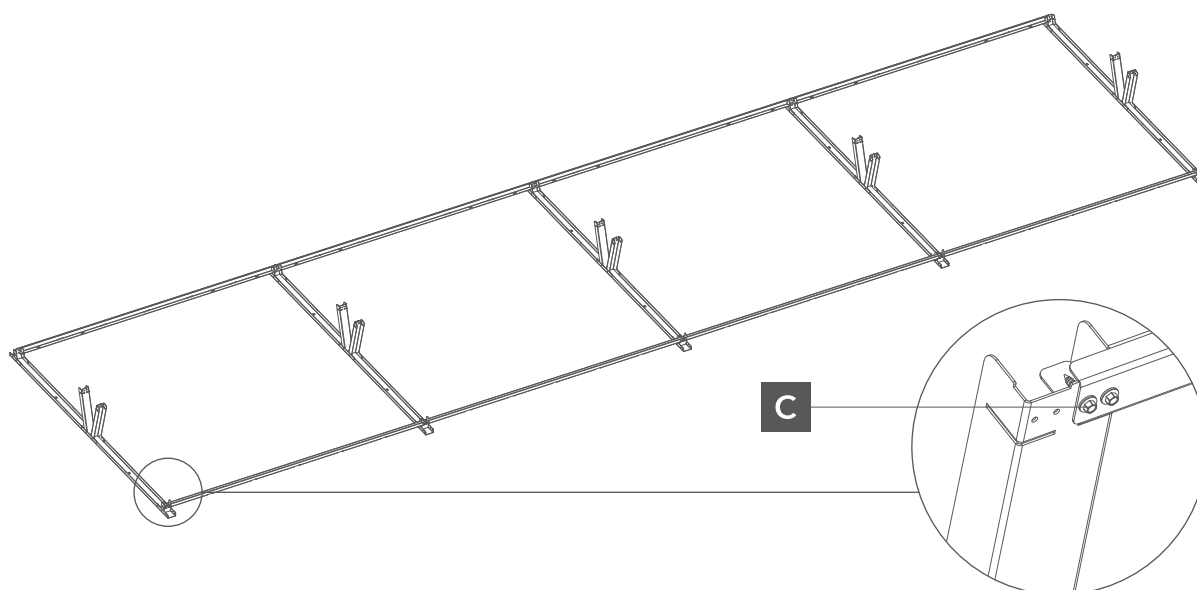
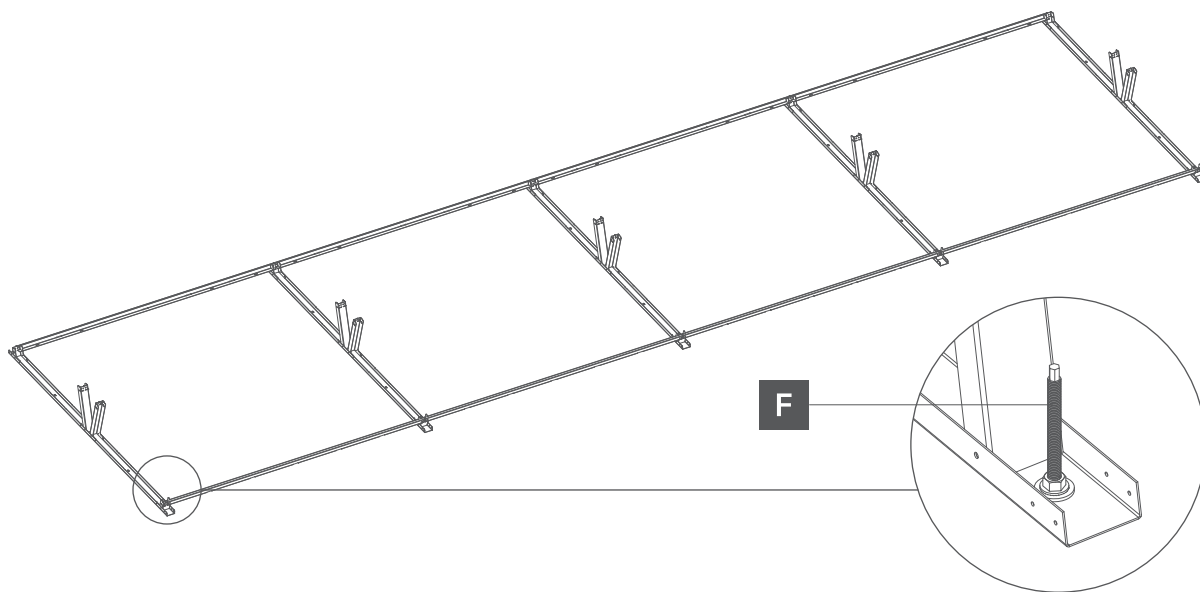

Fig. 3 Fastening the bracket to the mounting triangle

- 3** In the invasive system, the permanent connection of the mounting triangle to the roof is made by means of a double-threaded screw and a chemical anchor (Fig.4).



- 4** Slide the first, outermost photovoltaic module into the lower module holder, hold it firmly, slide the upper holder into the module and mount it with the mounting triangle.

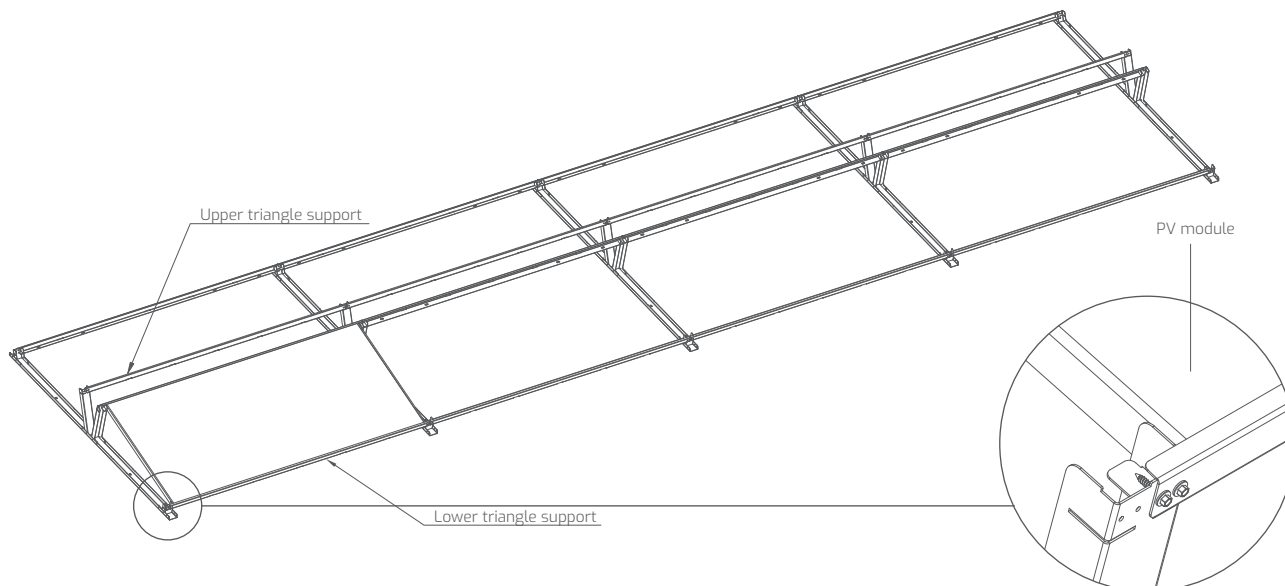

Fig. 4 Fastening the modules to the angle

- 5** If two or more rows of photovoltaic modules are to be installed, the mounting triangles must be connected with a connector (Fig. 5).

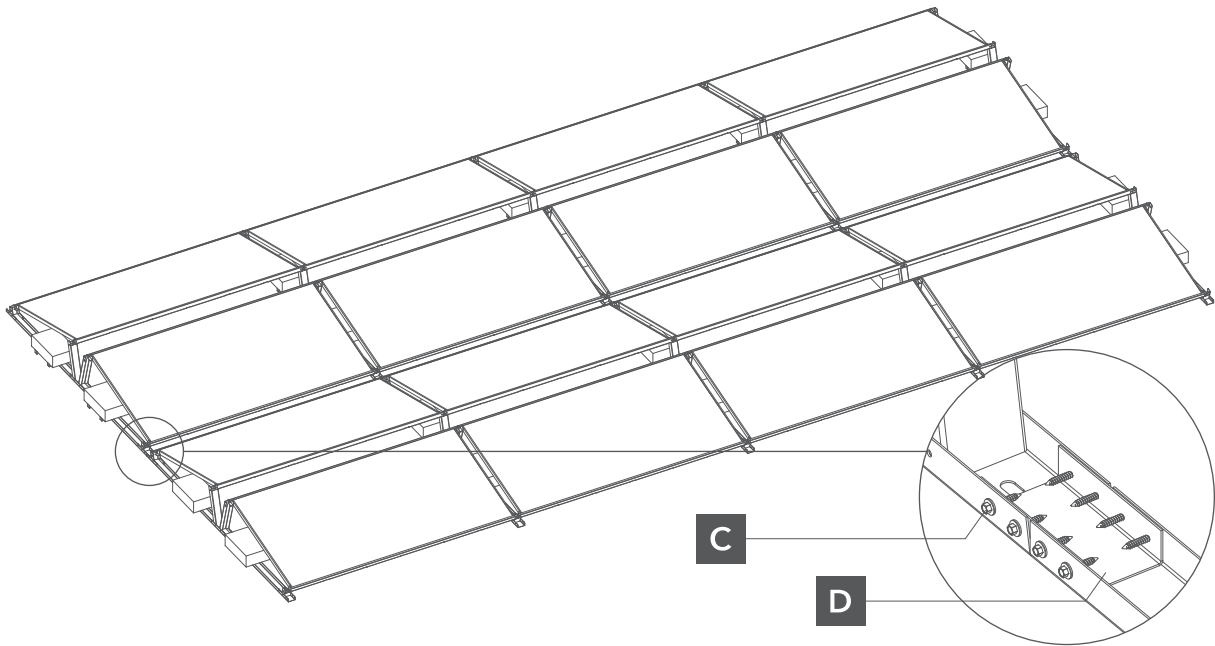

Fig. 5 Connecting the mounting triangles with a connector

Rechtsklausel

Diese Anleitung legt die grundlegenden Standards für die Montage und den Betrieb eines Unterstützungssystems für Photovoltaikmodule fest. Die Anleitung stellt kein und ersetzt kein Photovoltaikinstallationsprojekt dar. Die richtige Auswahl des Befestigungssystems für Photovoltaikmodule und der Bestandteile, die dazugehören, liegt in der Verantwortung der Personen, die die Montage dieses Systems direkt durchführen. Diese Arbeiten sollten von professionellen Installateuren mit den entsprechenden Qualifikationen und Erfahrungen durchgeführt werden. Es ist Aufgabe der Installateure, das richtige Befestigungssystem und dessen Integration mit dem Gebäude oder dem Boden in Abhängigkeit von den Bedingungen des Standorts und den Bedürfnissen des Kunden auszuwählen. IVENDO SOLAR, als Hersteller von Befestigungssystemen, übernimmt keine Verantwortung für die ordnungsgemäße Ausführung und Montage der Konstruktion. Es ist erforderlich, dass die technische Überprüfung der Installation mindestens einmal im Jahr durch Personen mit den entsprechenden Qualifikationen durchgeführt wird. Bei Auftreten von Witterungsanomalien (starke Windböen über 79 km/h, ungewöhnliche Schneemengen) sollte eine technische Überprüfung der Installation unverzüglich nach deren Ende durchgeführt werden. Die Konstruktion ist gemäß ihrem Zweck und den Anforderungen des Umweltschutzes zu nutzen. Es wird erwartet, dass die Konstruktion in einwandfreiem technischen Zustand gehalten wird und dass keine erhebliche Verschlechterung ihrer betrieblichen Eigenschaften und technischen Leistungsfähigkeit zugelassen wird. Änderungen und Modifikationen von Befestigungssystemen, die von IVENDO SOLAR hergestellt werden, einschließlich deren Schneiden, Schweißen, Verkürzens, Dehnens, Verringerung der in der Anleitung angegebenen Elemente, Erhöhung des Abstands der Tragpfosten, Erhöhung der Belastung der Systeme oder Verwendung von Systemen gegen ihren Zweck führen zu einem sofortigen Verlust der Gewährleistungsrechte und können die Lebensdauer der Systeme verkürzen und ihre sichere Nutzung einschränken.