



IVENDO Solar
ul. Wojska Polskiego 2D
14-200 Iława

Manual for system installation on a pitched roof

KDS-T2

These instructions contain information on mounting the mounting structure for 4 vertically arranged modules.

Materials:

- Stainless steel A2
- Aluminum 6060 T66



It is essential that you familiarize yourself thoroughly with the instructions and use them in accordance with the intended purpose.

Information about the security

Before starting the assembly work, you should familiarize yourself with the following safety instructions, which will reduce the risk of an accident.



Attention! The setup and connection should be performed by qualified personnel with the appropriate authorizations. The general safety rules must also be observed.



Attention! During the work, it is necessary to observe the applicable national and European standards, especially the electrical installations. It is also necessary to follow the instructions of the other components, e.g. the inverter.



Attention! Danger of falling from heights. The rules for working at heights and the necessary safety equipment such as harnesses and safety ropes must be observed.



Attention! Danger of falling objects. Special care must be taken. Before starting work, the assembly area must be appropriately secured to avoid hazards.



Attention! Warning of electric current. Be especially careful when performing electrical work, especially when connecting modules and when setting up and connecting the inverter to the modules.



Attention! Warning about highly flammable materials. Photovoltaic modules, inverters and other electrical equipment should not be used near easily flammable materials.



Attention! The assembly work must not be carried out by persons under the influence of alcohol or other intoxicating substances.



Attention! The mounting structure should not be installed simultaneously with the edge of the roof. It is recommended to keep a distance of at least 20 cm from the edge. The construction and modules should not be mounted outside the roof area.

Components overview

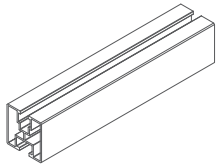
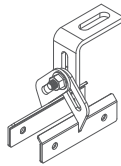
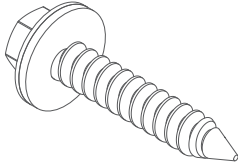
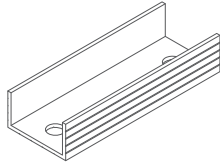
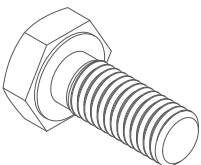
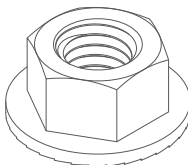
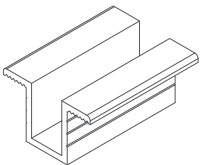
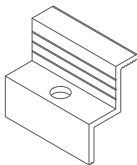
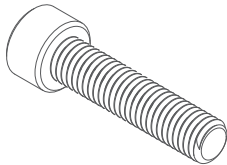
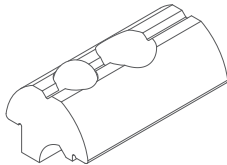
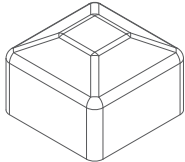
A 	ECO SMA rail <u>40x40x1,5</u> 4 piece <i>Material: Aluminium</i>	B 	adjustable Trapeze holder DT <u>12 piece</u> <i>Material: Stainless steel</i>
C 	Sheet screw with narrow thread M6 <u>24 piece</u> <i>Material: Stainless steel</i>	D 	Rail connector <u>6 piece</u> <i>Material: Aluminium</i>
E 	Hexagon head screw M10 <u>24 piece</u>	F 	Muffle groove M10 <u>24 piece</u> <i>Material: Stainless steel</i>
G 	middle Clamping bracket <u>12 piece</u> <i>Material: Aluminium</i>	H 	End clamp <u>8 piece</u> <i>Material: Aluminium</i>
I 	Allen screw M8 <u>20 piece</u> <i>Material: Stainless steel</i>	J 	sliding slot stone M8 <u>20 piece</u> <i>Material: Aluminium</i>
K 	Rail plug <u>8 piece</u> <i>Material: plastic</i>		

Assembly instruction



Necessary tools:

- Allen wrench (size 5)
- Ring wrenches (size 13, 15 and 17 mm)
- Cordless screwdriver with Torque adjustment
- Cross-recess bits / attachments for the Cordless screwdriver (PZ)



Tightening torques:

- Tighten middle and end clamps with a tightening torque of 8.5 Nm
- Tighten M8 bolts and nuts with a tightening torque of 18 Nm.
- Tighten M10 bolts and nuts with a tightening torque of 36 Nm



Staffing for assembly:

- At least 2 persons



Assembly time:

- About 2 hours

Control and maintenance

During the installation work, it must be ensured that the photovoltaic system is used according to its intended purpose. All changes in the use of construction elements, including connection with elements that do not come from IVENDO Solar, the modification of the construction by welding, shortening, lengthening, drilling, etc., and increasing the load on the systems will result in the loss of warranty claims and may have a direct impact on the life of the systems and their safe use.

The technical inspection and maintenance of the mounting system should be carried out at least once every six months, special attention should be paid to:

- Bolted connections,
- The condition and connections of the electrical cables are checked,
- the visual condition of the PV modules (contamination, mechanical damage) is checked.

Assembly of the set

- 1 Before mounting, it is necessary to determine the distribution plan of the modules on the roof (Fig. 1). This is the basis for the distribution of the mounting rails with all accessories (Fig. 2).

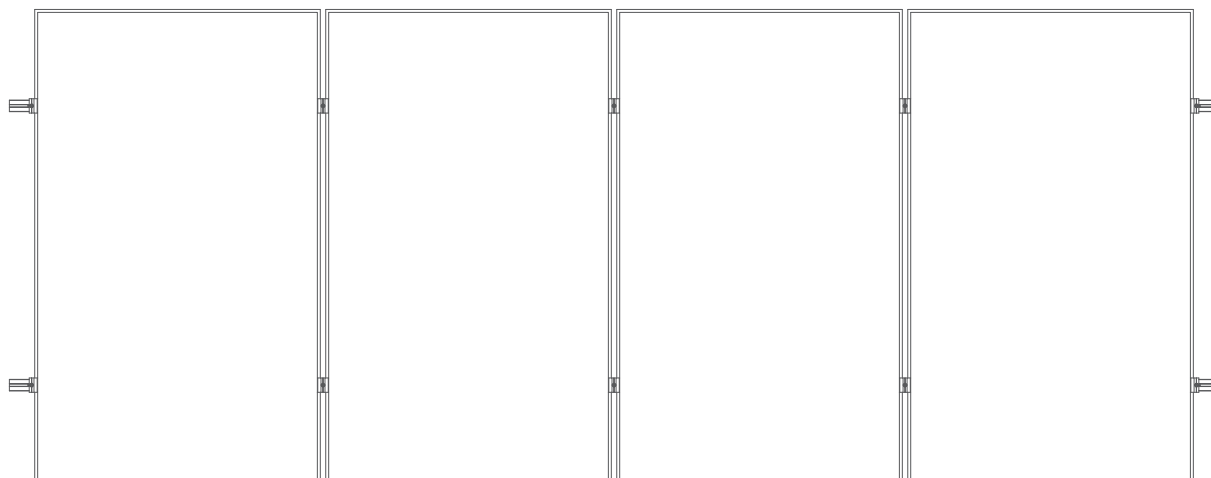

Fig. 1. module placement plan

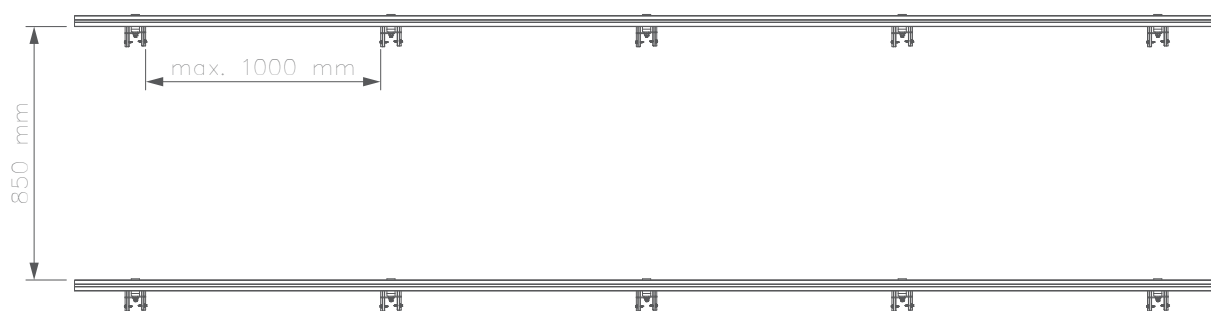

Fig. 2. arrangement of the mounting rails with roof attachment

- 2 In the places determined in this way, the roof brackets should be mounted. The bracket is attached to the wood with at least three TCS screws.

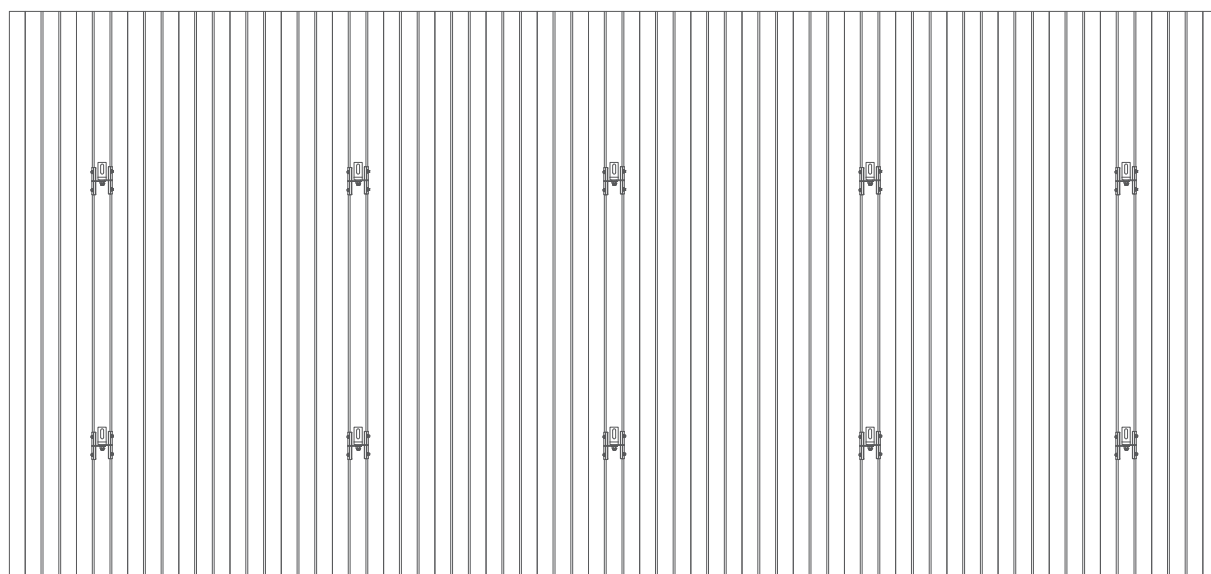

Fig. 3. determination of the mounting location for load-bearing structural supports.

- 3** The trapezoidal holder is fastened to the roof plate with four screws with a tight thread (Fig. 4).

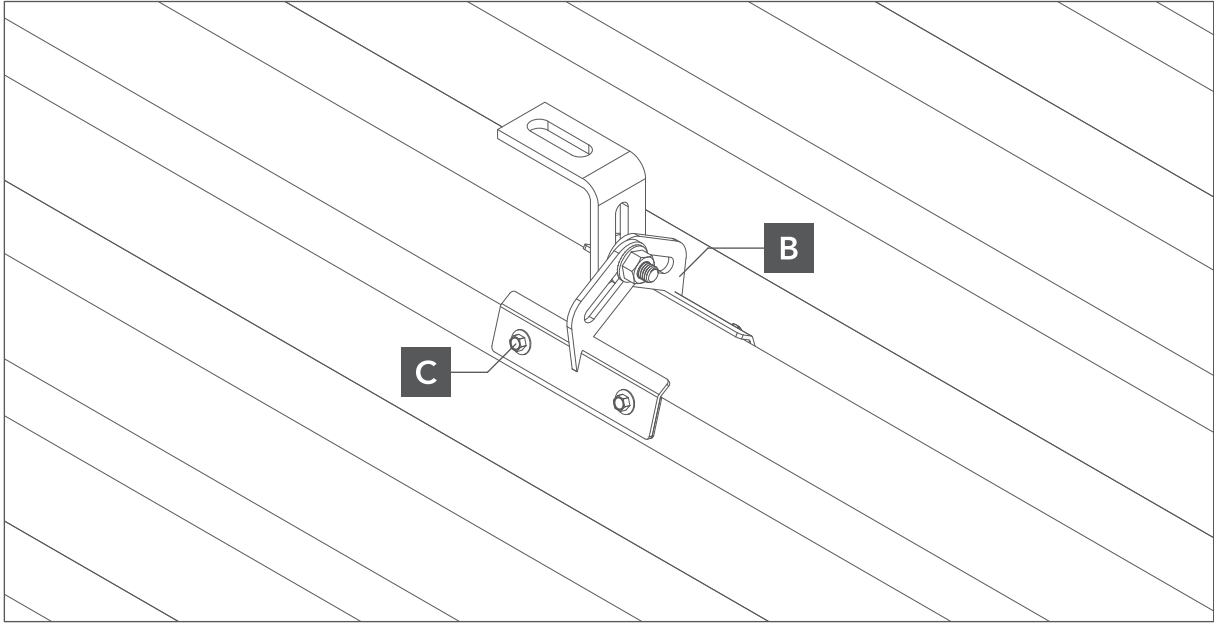

Fig. 4. fastening of the trapezoid holder

- 4** If a system with several rows is ordered, the mounting rails may have different lengths. They must be joined together using a rail connector joined together (Fig. 5).

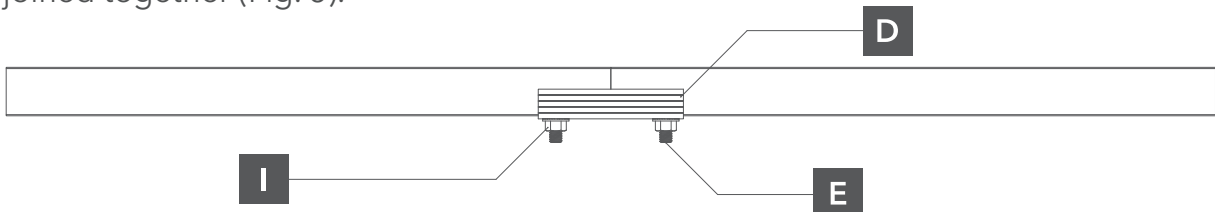

Fig. 5. connection of the mounting rails

- 5** Next, insert a DIN 6923 M10x25 bolt through one end of the mounting rail, make it fit with the trapezoidal holder and fasten it with the DIN 6923 M10 nut (Fig. 6).

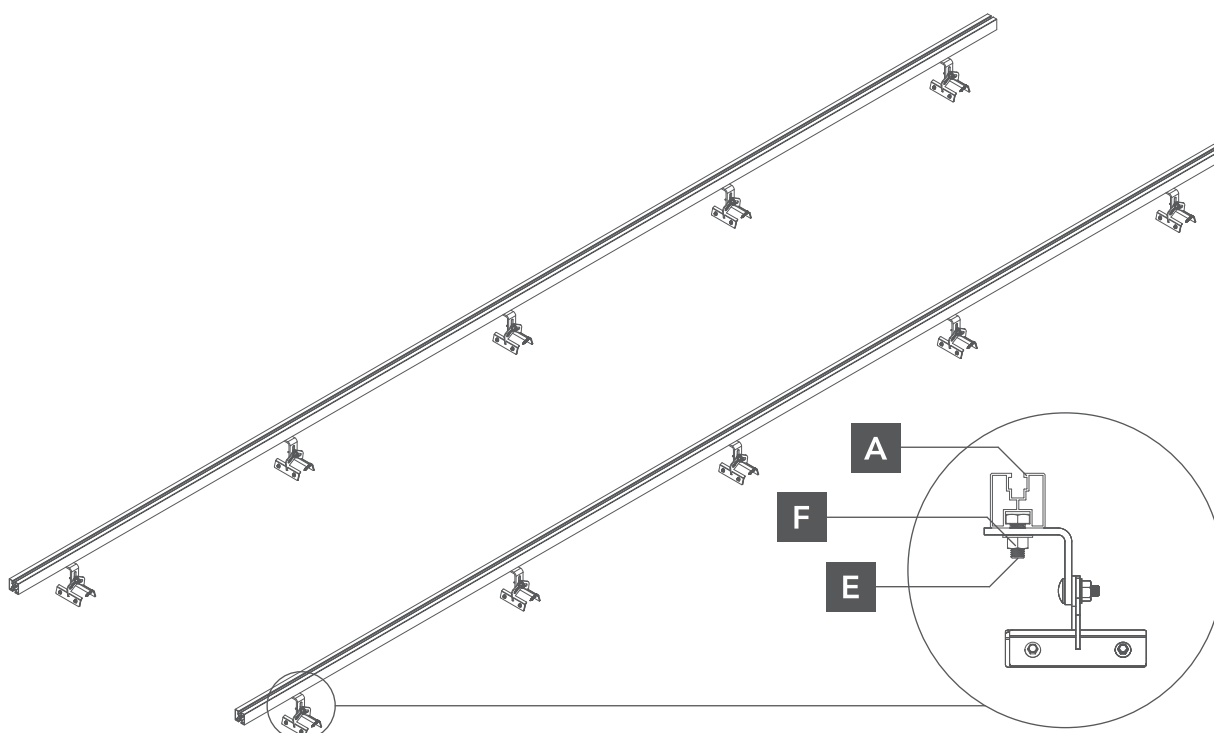

Fig. 6. fastening of the mounting rail to the mounting bracket

- 6** On the mounting rails we put the first outer photovoltaic module and we fix the end clamps by fastening them with allen screws M8 and slot nut M8. Then we install the middle clamps without fixing them. After the next modules are installed, the middle clamps can be fastened. This process should be repeated until all modules are mounted in a row (Fig. 7).

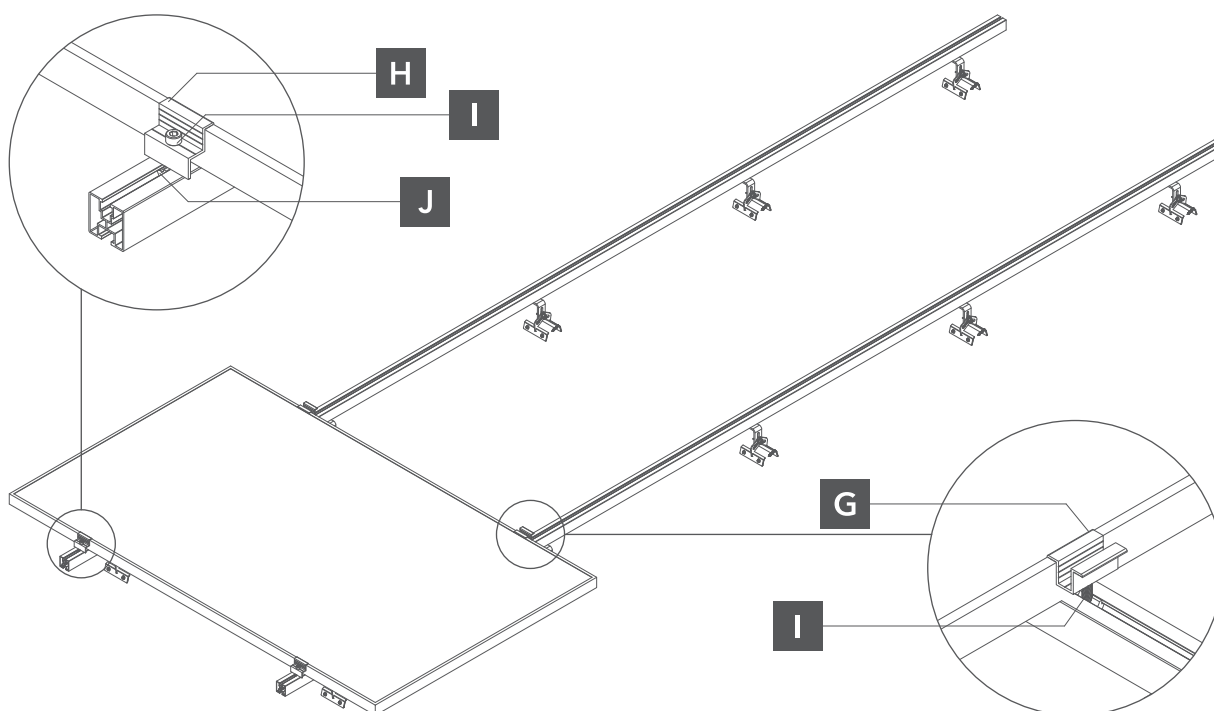

Fig. 7. attachment of the module to the mounting rail.